

PLAN

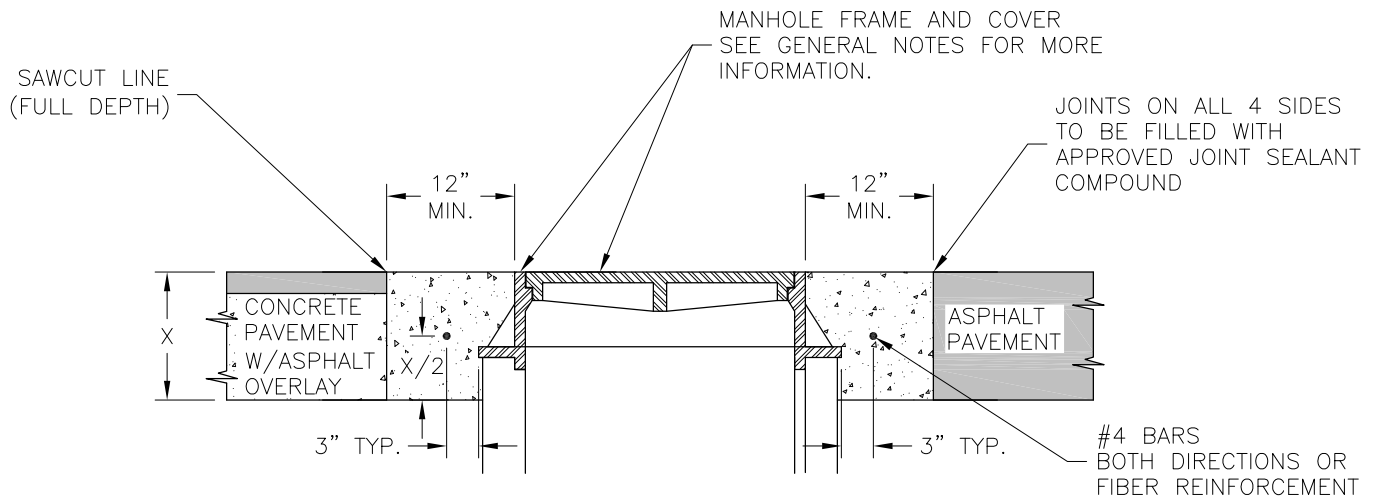

SECTION A-A

GENERAL NOTES

- 1.) ADJUST MANHOLE FRAME AND COVER TO FINISH GRADE AND SLOPE WITH CONCRETE ADJUSTMENT RINGS AND LEVELING MORTAR AS REQUIRED.
- 2.) THE ORIENTATION OF THE REINFORCED CONCRETE COLLAR SHALL BE DETERMINED BY THE ENGINEER IN THE FIELD.
- 3.) ALL ITEMS SHOWN ABOVE ARE SUBSIDIARY TO THE BID ITEM "MANHOLE ADJUSTMENT".

CITY OF LAWRENCE, KANSAS
STANDARD MANHOLE ADJUSTMENT DETAILS

04/19/2007